

EQUIPARTS PARTITION CHECK LIST

WHEN ORDERING OR QUOTING PARTITIONS, PLEASE SUBMIT THE FOLLOWING INFORMATION ON A DRAWING OF THE LAYOUT OF THE ROOM:

1. MATERIAL OF NEW PARTITIONS
2. COLOR OF NEW PARTITIONS
3. SPECIFY HEADRAIL BRACED, CEILING HUNG, OR FLOOR SUPPORTED
4. FINISHED WALL DIMENSIONS OF ROOM
5. C x C DIMENSIONS BETWEEN FIXTURES (IF POSSIBLE)
6. A.D.A. REQUIREMENTS ??
7. DOOR SWINGS
8. LOCATION OF OBSTRUCTIONS (RADIATORS, WINDOWS, FLOOR DRAINS, ETC.)

BELOW IS AN EXAMPLE OF WHAT THE FINISHED PICTURE SHOULD LOOK LIKE:

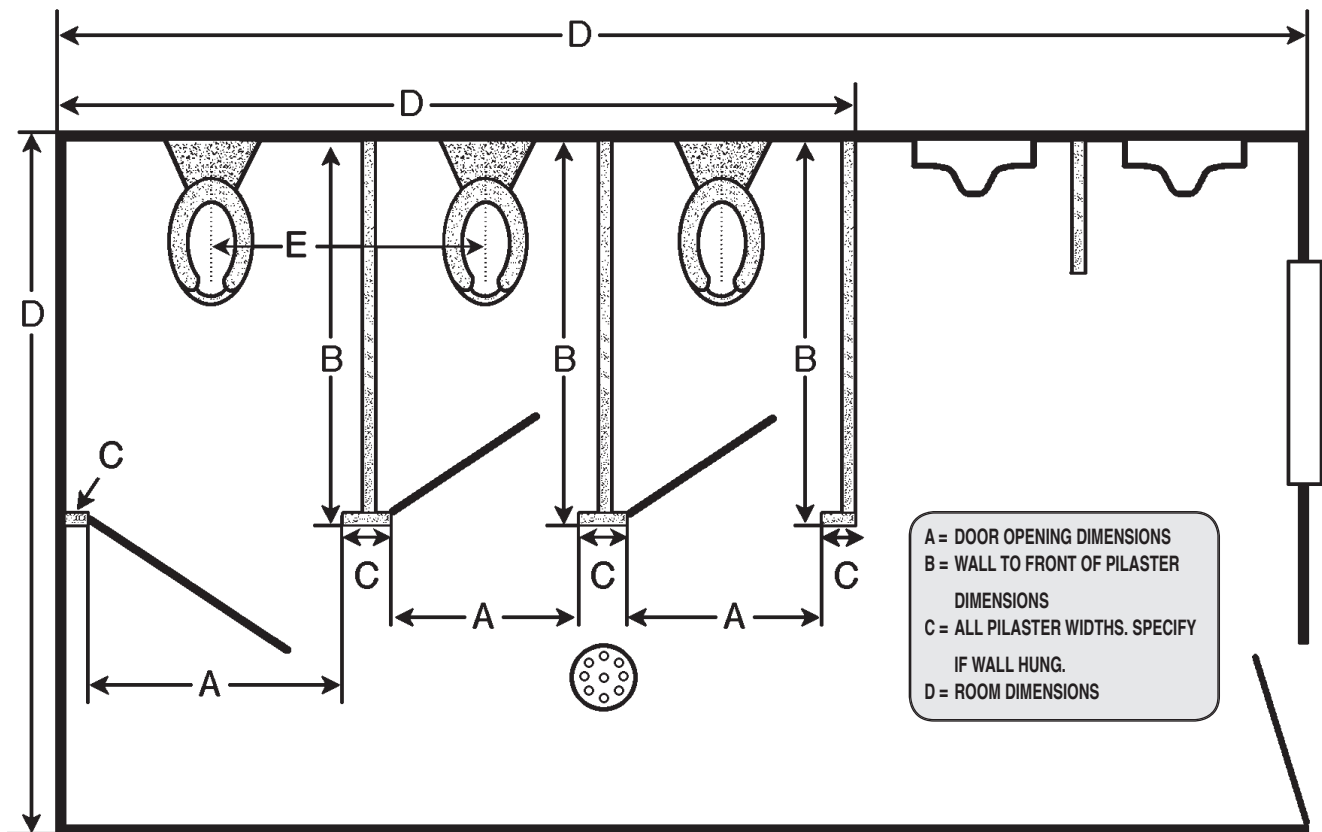

EQUIPARTS
Repair Parts Specialists®

PITTSBURGH (412) 781-9100
TOLL FREE (800) 442-6622
FAX (412) 781-3085